

COMMERCIAL REFRIGERATORS, STAINLESS STEEL PRODUCTS

**REFRIGERATORS  
OPERATING INSTRUCTIONS**

## **EN - CONTENTS**

1. Transportation – Positioning – Installation	3
2. Starting up	3
3. Safety instructions	4
4. Temperature regulation	4
5. Defrosting	4
6. Temperature alarm	5
7. Fault codes on the display	5
8. Cleaning – Maintenance	5
9. Temporary function interruption	5
10. Saving energy advices	5
11. Troubleshooting	6

## 1. Transportation – Positioning – Installation



**Keep the appliance in an upright position during the transportation in order to avoid critical damage in its systems.**

Remove all packaging. Move carefully the device to its final position. If the floor is not flat regulate the legs, to ensure that the appliance is balanced.



**To ensure efficient operation do not place it near heat sources. The appliance is designed to operate in an ambient temperature of up to 40 °C.**

Power must be connected via a wall socket. The appliance is supplied with an electric plug, SHUKO type.



**Current taps and plugs always must be provided with ground.**

If the device has a showcase remove the packaging among the crystals and move the side crystals unscrewing the screws pointed at the picture, so that the crystals line-up with the front crystal of the show case.

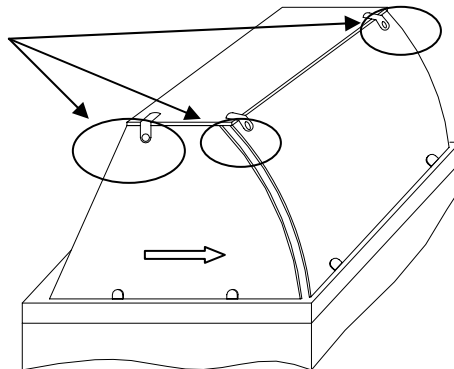

## 2. Starting up





Press the on/off switch. The figure that appears in the display shows the actual temperature in the cabinet and indicates that power is connected. The motor starts after 2 minutes.



**Do not store products in the appliance until its temperature reaches at the required point. Do not fill at once your appliance with big quantities of products.**

### 3. Safety instructions

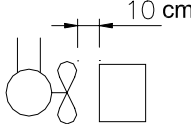
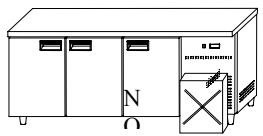
For your safety and the proper function of the appliance please follow the instructions below:

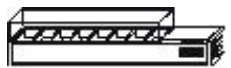
	Store all products to be preserved so as not to obstruct the air circulation among the shelves of the appliance.
	Do not store hot food or hot drinks in your appliance.
	Place products at least 10cm away from the fan, otherwise the refrigeration in the appliance will be impaired.
	Do not cover the intake air slots.
	Cover the food with a plastic film before storing it into the appliance.
	Do not operate pizza refrigerated show cases without gastronorm pans covering the whole cooling space.

### 4. Temperature regulation



Press to see the temperature setting.

If you wish to change keep this key pressed and change it by pressing the arrows [▼] or [▲] accordingly.

### 5. Defrosting

#### Refrigerators

Defrosting is automatically performed six times every 24 hours. It can also be performed manually by pressing the key [set]. If the refrigerator is on heavy load conditions (frequent door opening) manual defrosting may become necessary.

Condensate water is led through a tube to a tray, where it is evaporated by a pipe from the refrigeration system placed in the tray.

#### Freezers

Defrosting is automatically performed four times every 24 hours. It can also be performed manually by pressing the key [set]. If the freezer is operating on heavy load conditions manual defrosting may become necessary.

Condensate water is led through a tube to the drainage kit, where it is evaporated by a resistance, controlled by the water level

## 6. Temperature alarm

If the temperature in the appliance is higher or lower than the limits set, then an “ALR” indication flashes on the display. Filling with big quantities of products at once, or leaving the door open for long periods will cause the temperature to rise and produce an alarm effect.

## 7. Fault codes on the display

### 7.1 Refrigerators

[ALo]: Low temperature alarm  
[AHi]: High temperature alarm  
[LF1]: Sensor failure. If the sensor fails, the compressor remains on for 4 minutes and off for 4 minutes. Technical assistance should be requested.

### 7.2 Freezers

[ALO]: Low temperature alarm  
[AHI]: High temperature alarm  
[LF1]: Temperature sensor failure  
[LF2]: Evaporator sensor failure  
[doR]: Door opened

All alarm codes are also audible.

## 8. Cleaning – Maintenance

Frequent cleaning is highly recommended. Do not use sharp or other similar objects which may damage your appliance. Clean the inside surfaces with a mild soap solution or a detergent without chlorine.

Also clean the external surfaces using steel oil.



**Do not use detergents or substances based on chlorine or acid solvents. These may cause corrosion of stainless steel surfaces.**

Keep the compressor and the condenser free from dust and dirt, otherwise, the efficiency of the refrigerator will be reduced. Cleaning is best done with a vacuum cleaner and a brush. Before you proceed to any cleaning or maintenance, disconnect the plug from the electrical supply.

## 9. Temporary function interruption

In case you wish to turn the appliance off for a while, in order to keep it in the best possible condition, follow the instructions below:

Turn the appliance off and disconnect from the electrical supply. Empty the appliance and clean it as indicated above. Keep the doors open in order to avoid unpleasant odors.

## 10. Saving energy advices

- Open the appliance's doors according to your needs but please **do not do** that pointlessly. They must remain open the less possible there can be.
- Check regularly that the appliance's doors are solidly closed and that the door seals are in good condition.
- Do not place your appliance near heat sources or points with high sun radiation.
- Do not fill at once your appliance with big quantities of products, because this will increase energy consumption.

## 11. Troubleshooting

Malfunction	Possible cause	Solution
The appliance does not cool	<ul style="list-style-type: none"> <li>• There is ice in the evaporator</li> <li>• The products are obstructing the air flow</li> <li>• The room temperature is very high</li> </ul>	(See case 2) Remove the products which obstruct the air flow of the evaporator Improve the temperature condition of the room
Ice in the evaporator	<ul style="list-style-type: none"> <li>• The temperature adjustment is very low (refrigerators)</li> <li>• High humidity environment</li> <li>• Humid products have been placed in the refrigerator (ex. Vegetables)</li> <li>• The doors are opened frequently and for a long time</li> </ul>	Check the temperature adjustment. Increase the temperature setting. Improve the environment condition. Increase the defrost frequency. Cover the food with a plastic film before putting it in the refrigerator. Increase the defrost frequency and duration. Decrease the open door duration as possible. Increase the defrost frequency.
Water in the appliance	<ul style="list-style-type: none"> <li>• The drainage pipe has been sealed</li> </ul>	Clean the drainage pipe
Water in the gastronorm pans (open top refr.)	<ul style="list-style-type: none"> <li>• High humidity environment</li> </ul>	Increase the setting temperature

In any case of malfunction contact the dealer of our company describing the problem, denoting the type and the serial number (S/N) of your appliance.

All the technical characteristics necessary are specified on the identification tag positioned to the right of the device.

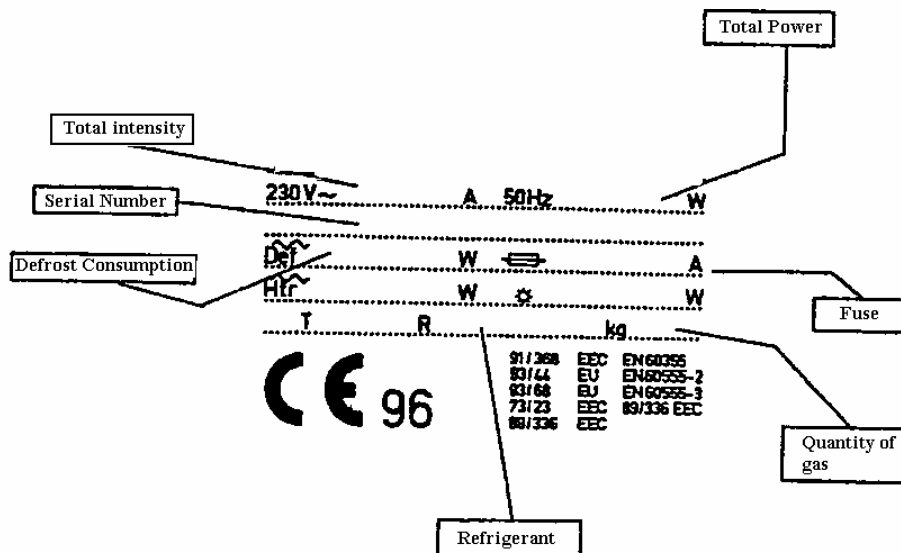

- 1) Push [ ← ] to enter the parameters menu. The first parameter (SPo) shows up. Scroll the parameter list by pressing key [ ▼ ] or [ ▲ ].
- 2) Press [set] to display a parameter value and modify it by pressing the arrows. Press [ ← ] to save the new value.
- 3) To exit the parameter menu press [ ← ].
- 4) On/off switch: Press  for 3 seconds to switch the device off.  
 T2 (▲): Press to see the evaporator temperature.  
 Reset (▼): In case of alarm situation, press to reactivate.  
 Df (set): Press [set] for 4 seconds to start a manual defrost cycle.

Alarm messages:

- ALo: Low temperature alarm                      AHi: High temperature alarm  
 LF1: Room sensor failure                      LF2: Evaporator sensor failure  
 Dor: Open door alarm (when a door remains more than four minutes opened)

*PAMETER SETTINGS*

	<b>Code</b>	<b>Description</b>	<b>Minimum - Maximum Limits</b>	<b>Settings</b>
1	SPo	Temperature setpoint	LSP . . . HSP	-18
2	ALo	Low alarm threshold	-45 . . . 20 °C	-25
3	AHi	High alarm threshold	0 . . . 60 °C	0
4	Dr1	Defrost repetition time	1 . . . 100 h	6
5	Cod	Access code		22
6	DiF	Thermostat delay	1 . . . 20 °C	3
7	dd2	Defrost time out	0 . . . 100 min	18
8	dP3	Dripping time	0 . . . 15 min	0
9	dY4	Defrost display control	-1 . . . 40 min (-1: Displays Dfr while t>Spo+dif)	-1
10	dE5	Defrost end temperature	1 . . . 70 °C	+30
11	Dt6	Defrost type	0= ELE / 1=GAS	0
12	AF1	Alarm setting	0=Auto, 1=Manual	0
13	At2	Temperature alarm delay	-1 . . . 120 min (-1: alarm disabled)	30
14	Fo1	Fan restart temperature	-50 . . . 50 °C	-2
15	Ft2	Evaporator fan control	-1: Continuous function 0: Parallel with compressor 0-15 min: time fan stops after compressor	-1
16	Fd3	Ventilation in defrost	0: off 1: Starts when t2<Fo1 2: on	0
17	Co1	Compressor minimum on time	0 . . . 15 min	2
18	Cp2	Compressor minimum off time	0 . . . 15 min	2
19	CF3	Compressor control for T1 fault	-1: compressor off 0: compressor on 1-150 min: compressor on time	3
20	CF4	Compressor off time for T1 fault	1-150 min	3
21	SE1	Probe T1 offset	-20 . . . 20 °C	
22	SE2	Probe T2 offset	-20 . . . 20 °C	
23	SEr	-		0
24	LSP	Minimum temperature setting	-50 . . . 100 °C	-21
25	HSP	Maximum temperature setting	-50 . . . 100 °C	-10

Technical specifications:

Supply Voltage:	12V or 230V AC
Connectors:	6,3mm (DIN 46247)
Relay 250VAC:	30A Resistive Load
Relay 250VAC:	7A Resistive Load
Function temperature:	-10°C - +60°C
Storage temperature:	-20°C - +80°C
Supply fuse:	0,5A
Max. power:	3 Watts

Operating instructions:

- 5) Press [ **set** ] + [ ▼ ] + [ ▲ ] to enter the parameters menu. The first parameter (SP) shows up. Scroll the parameter list by pressing key [ ▼ ] or [ ▲ ].
- 6) Press [ **set** ] to display a parameter value and modify it by pressing the arrows. Press [ ↵ ] to save the new value.
- 7) To exit the parameter menu press [ ↵ ].
- 8) On/off switch: Press  for 3 seconds to switch the device off.  
Reset ( ▼ ): In case of alarm situation, press to reactivate.  
Dfrost: Press key [ **set** ] for 4 seconds to start a manual defrost cycle.

Alarm messages:

- ALo: Low temperature alarm  
AHi: High temperature alarm  
LF1: Room sensor failure  
Er: Memory fault. Proceed with the following:  
1) Press buttons [ ↵ ] and [ ▲ ].  
2) Set the thermostat 's parameters as described in the instructions manual.

PARAMETER SETTINGS

	Code	Description	Minimum - Maximum Limits	Factory settings
1	SP	Temperature setpoint	LSP . . . HSP	0
2	SL	Minimum temperature setting	-50 . . . 100 °C	-2
3	Sh	Maximum temperature setting	-50 . . . 100 °C	8
4	Di	Thermostat delay	1 . . . 8 °C	3
5	Cr	Compressor off time	0 . . . 4 min	2
6	CF	Compressor control for sensor fault	0= 40%: 3min on & 4 min off 1=100%: compressor on	0
7	dF	Defrost repetition time	0 . . . 100 h	4
8	dt	Defrost time out	1 . . . 90 min	18
9	dL	Defrost end temperature	1 . . . 20 °C	10
10	do	Defrost type	Electric / compressor off	0
11	dr	Dripping time	0 . . . 10 min	0
12	Td	Display in defrost	0 . . . 99 min	20
13	AJ	Probe T1 offset	-9 . . . 10 °C	
14	tS	Display slowdown	0 . . . 20 sec	0

The appliance is supplied on one year proper function warranty.

## ELECTRIC DIAGRAM FOR POSITIVE REFRIGERATORS

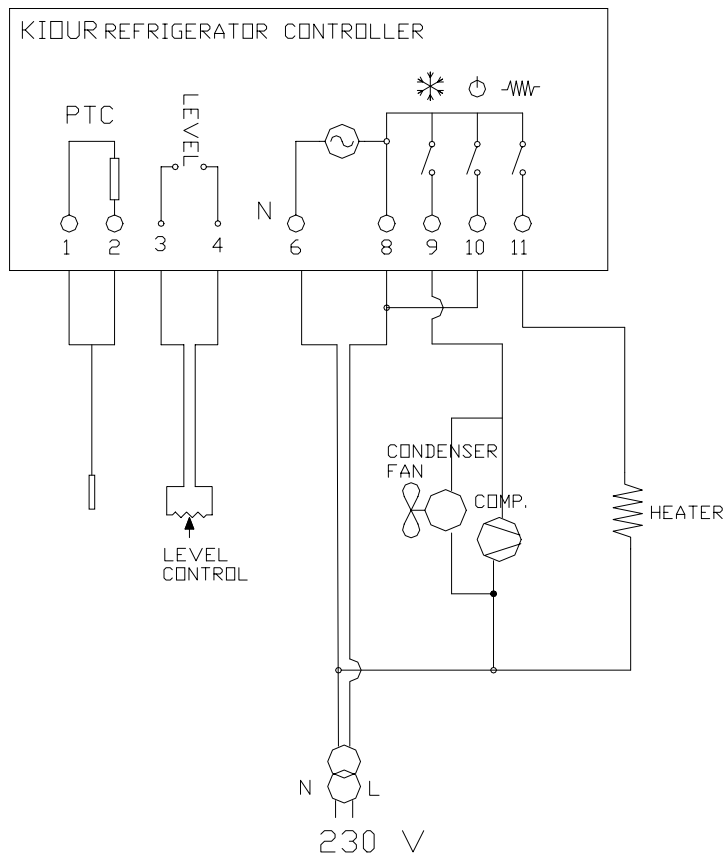

## ELECTRIC DIAGRAM FOR FREEZERS (KIOUR - FR)

